

05 - 2008 | M. SA.

AGGIORNATO al: 04 Maggio 08

2 - Hood

CODE	DESCRIPTION
120304	DOOR MICROSWITCH
150819	CABLE HOLDER PG16 WITH HOLE
150849	PASSAC. RIGIDO TUBI FC2006
150850	FERMATUBO PRESS.A MOLLETTA
160542	SCREW SUPPORT
160552	SPRING SUPPORT
160553	SCREW
190679	PIN
200219	RUBBER GASKET
210207	FOOT BHC
260201	SCREW TCP 3X10
260206	SCREW TCP 4X22
260715	SCREW 3,5X16
322873	COVER FCM
323154	DOOR FC3
323163	DOOR FC4
330893	BUSH
340416	PIN
341218	HINGE PIN B-F-G
342321	HOOD FC4
342322	HOOD FC3
352029	RIGHT SIDE PANEL
352030	LEFT SIDE PANEL FC4
352031	RIGHT SIDE PANEL FC3
352032	LEFT SIDE PANEL FC3
352033	FRONT PANEL FC2006
390188	BACK PANEL
390189	BACK PANEL FC3
391334	SPRING FOR DOOR FC4
391335	DOOR CATCH SPRING
391336	DOOR SPRING FC3
450821	SPRING CLIP FASTENER SNU 3634

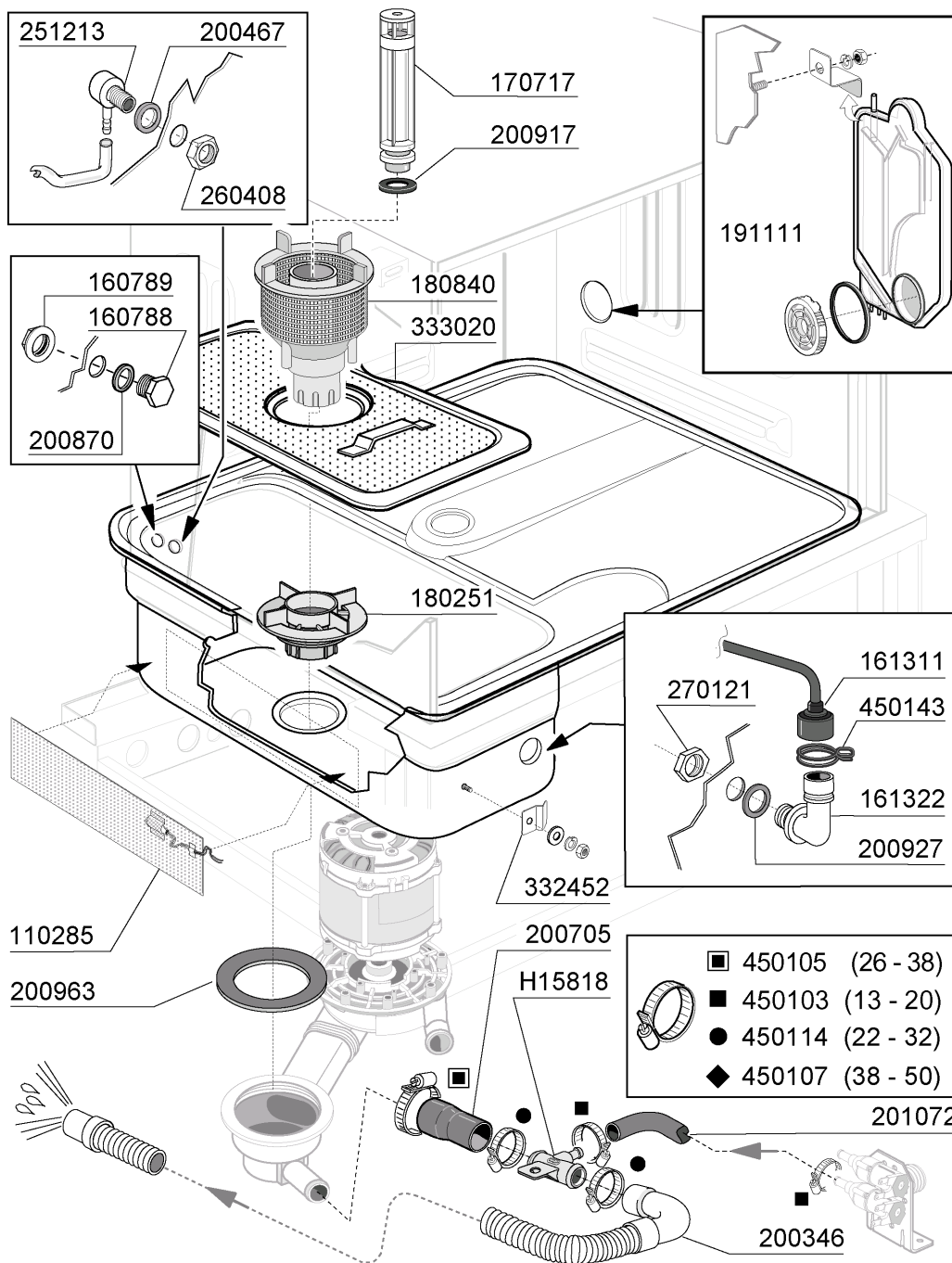

AGGIORNAMENTO al: 08 MAGGIO 08

05 - 2008 | M. SA.

3 - Tank

CODE	DESCRIPTION
110285	HEATER 500W
160788	PLUG
160789	NUT
161311	HOSE FOR AIR CHAMBER BC-BR-AC9
161322	AIR TRAP FC2006
170717	OVERFLOW PIPE FC2006
180251	FIXING NUT FOR PUMP FC2006
180840	FCM FILTER
191111	BREAK TANK (SOFTENER)
200346	DRAIN HOSE GLASSWASHER
200467	DUTRAL GASKET F. AIR TRAP
200705	BOILER EXIT HOSE
200870	GASKET 18X10X2
200917	GASKET FOR OVERFLOW PIPE BR-BC
200927	GASKET FOR AIR TRAP
200963	JOINT 110X88X3
201072	HOSE
251213	INJECTIOR S/S FOR DETERGENT IN
260408	S/S NUTS D.12
270121	NUT FOR AIR TRAP
332452	BRACKET
333020	TANK FILTER FC2006
450103	CLAMP FE ZN. 13-20 H=9
450105	CLAMP FE ZN. 26-38 H=12,2
450107	CLAMP FE ZN 38-50 H=12,2
450114	CLAMP FE ZN.22-32 H=12,2
450143	CLAMP D.39,7 X 37,7
H15818	DISCHARGE VALVE

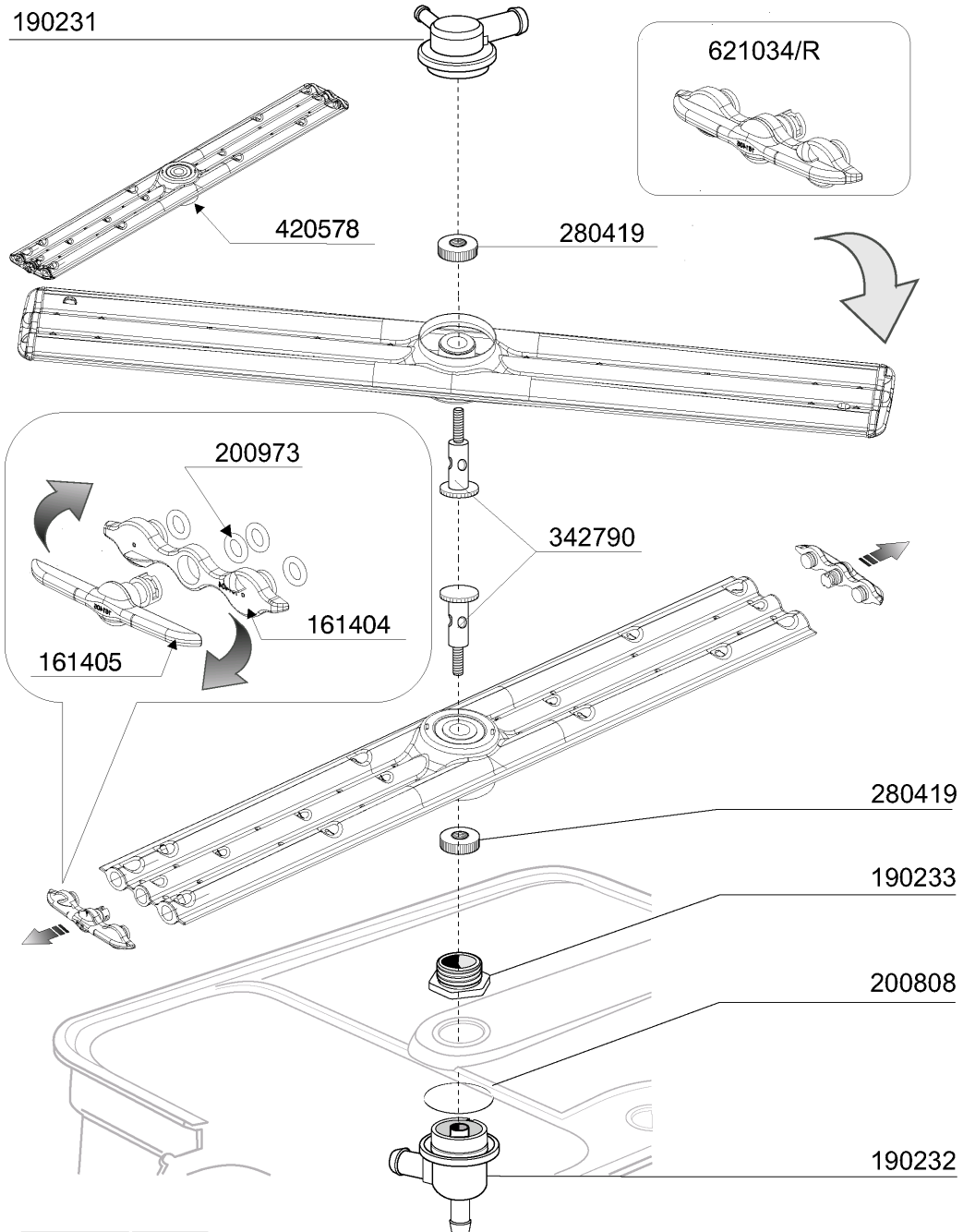

01-2011 M. SA.

4 - Wash arm

CODE	DESCRIPTION
161404	PLUG
161405	PLUG
190231	UPPER ARM SUPPORT FC2006
190232	LOWER ARM SUPPORT FC2006
190233	ARM SUPPORT
200808	OR GASKET 3,53X50,80X57,86
200973	JOINT OR 1.78X5.28
280419	LOCK NUT
342790	RINSE SUPPORT
420578	WASH AND RINSE ARM FC2006
621034/R	ARM PLUG

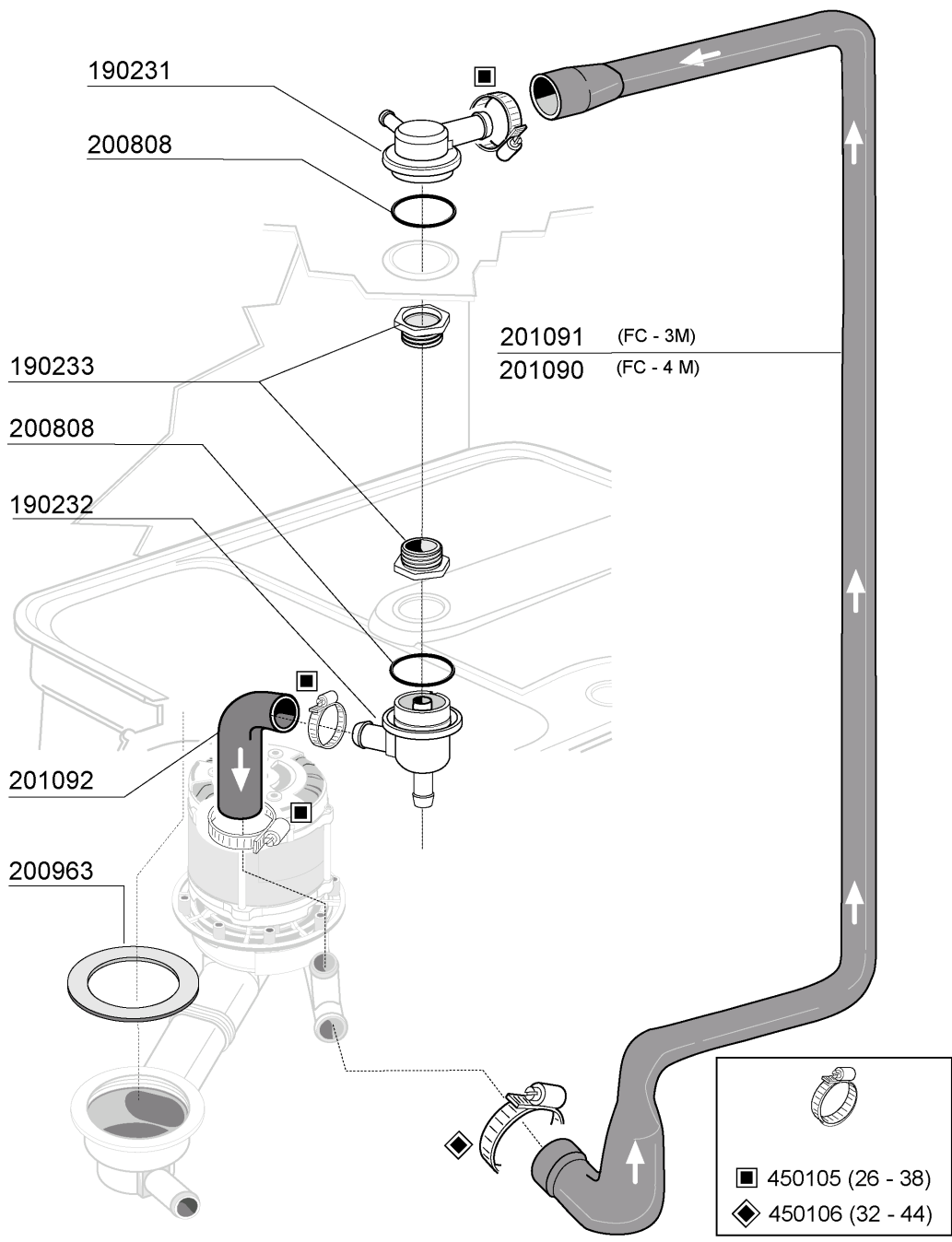

AGGIORNAMENTO AL: 22 Aprile 08

04 - 2008 | M. SA.

5 - Wash

CODE	DESCRIPTION
190231	UPPER ARM SUPPORT FC2006
190232	LOWER ARM SUPPORT FC2006
190233	ARM SUPPORT
200808	OR GASKET 3,53X50,80X57,86
200963	JOINT 110X88X3
201090	UPPER WASH HOSE FC4
201091	WASH HOSE FC3
201092	LOWER WASH HOSE FC
450105	CLAMP FE ZN. 26-38 H=12,2
450106	CLAMP FE ZN 32-44 H=12,2

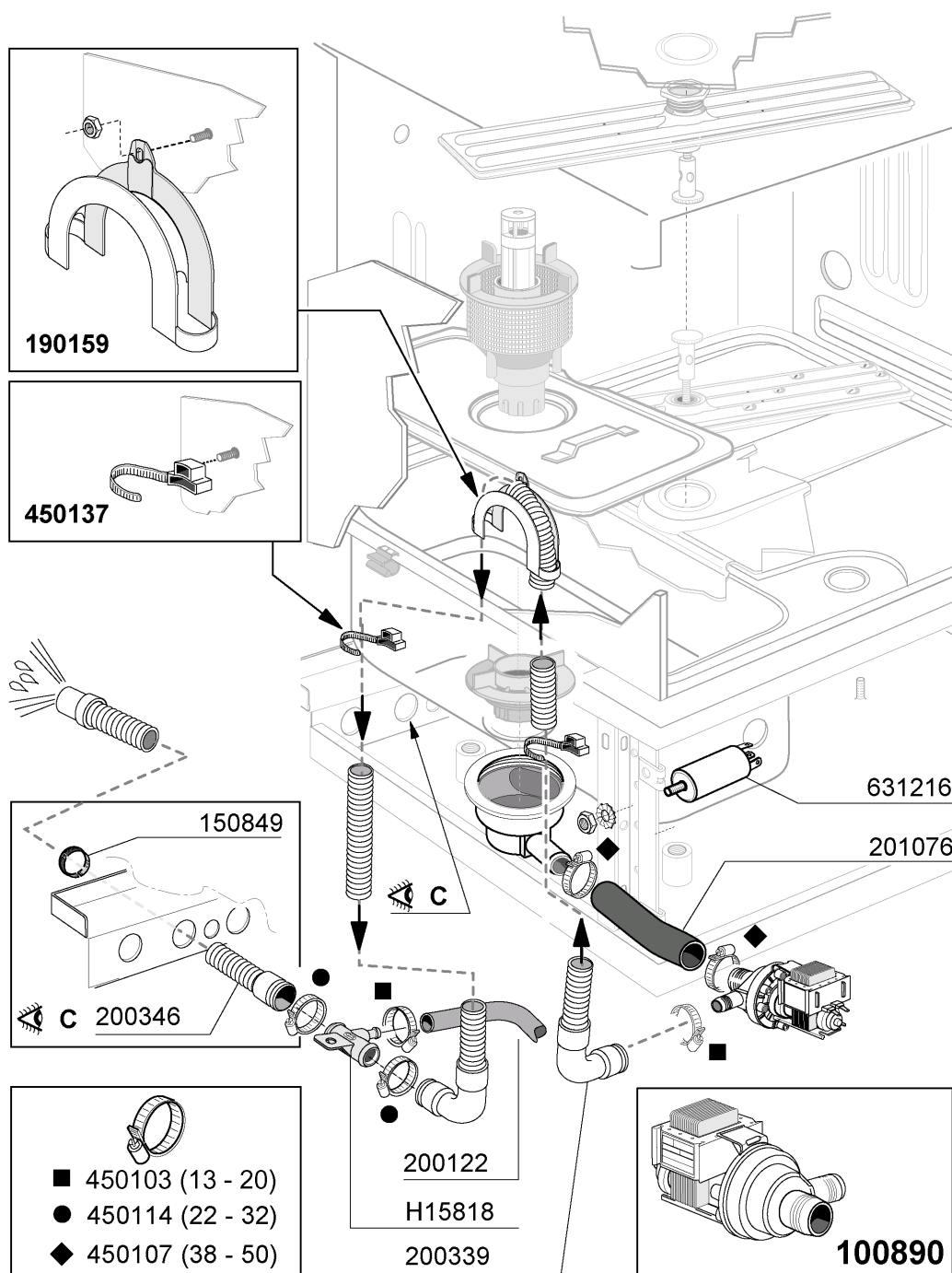

AGGIORNAMENTO al: 08 MAGGIO 08

05 - 2008 | M. SA.

6 - Drain pump

CODE	DESCRIPTION
100890	DRAIN PUMP 30W 220/50
150849	PASSAC. RIGIDO TUBI FC2006
190159	DRAIN HOSE SUPPORT FCM/FCMA
200122	HOSE 11X19
200339	DRAIN HOSE (DRAIN PUMP)
200346	DRAIN HOSE GLASSWASHER
201076	HOSE
450103	CLAMP FE ZN. 13-20 H=9
450107	CLAMP FE ZN 38-50 H=12,2
450114	CLAMP FE ZN.22-32 H=12,2
450137	COLLAR CONNECTION WITH BASE 31
631216	CAPACITOR 6.3 MF 450V
H15818	DISCHARGE VALVE

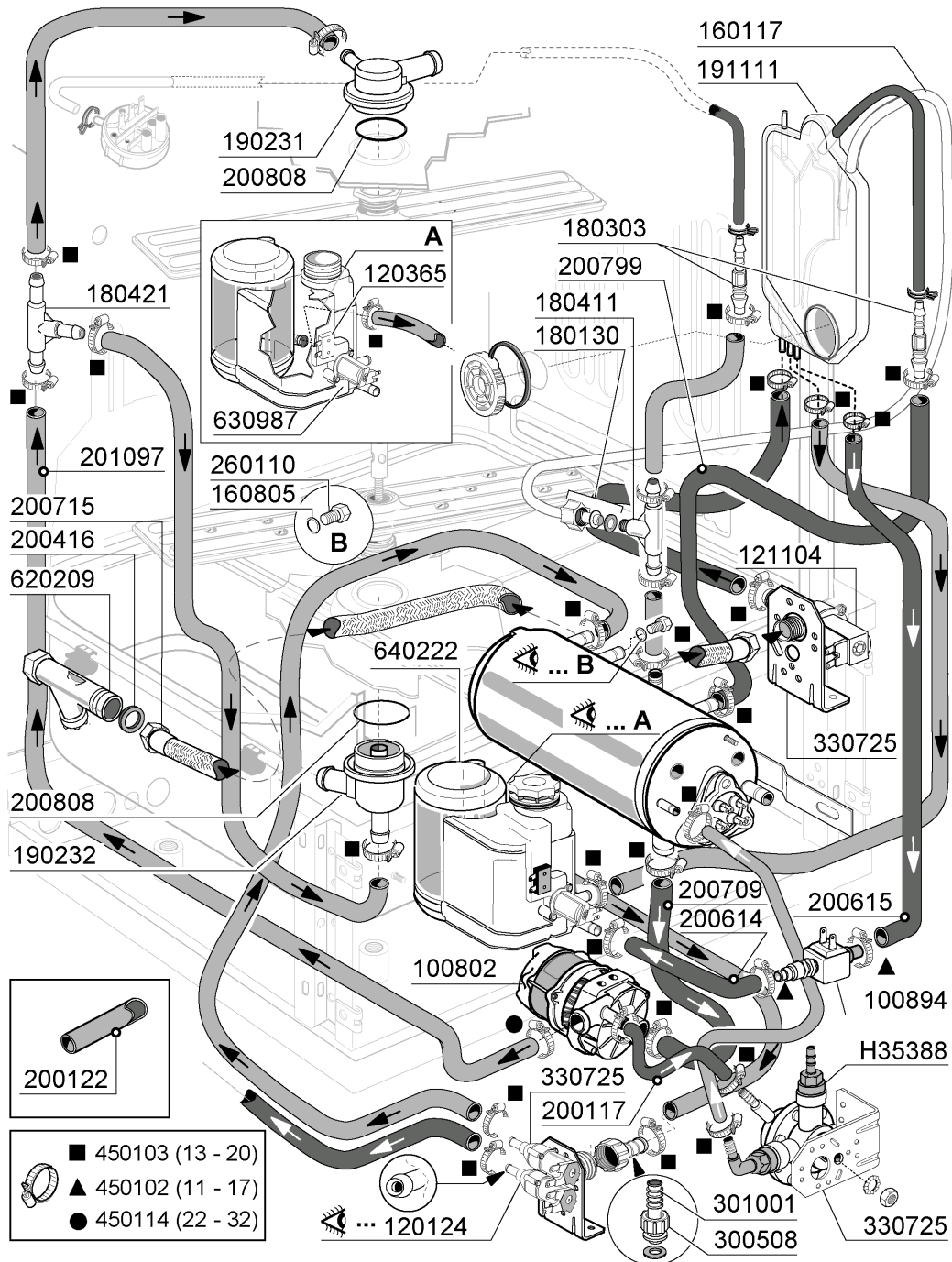

AGGIORNAMENTO al: 14 LUGLIO 08

06 - 2008 | M. SA.

7 - Rinse

CODE	DESCRIPTION
100802	PUMP HP 0,3 230V-50HZ
100894	RINSE PUMP
120124	2-WAY SOLENOID VALVE 230V 90°
120365	MICROSWITCH FOR SOFTENER
121104	SOLENOID VALVE 8 LT/M
160117	HOSE 6,3X1,1 WITHE
160805	GASKET D.8
180130	CONNECTION NUT FOR BY PASS (1/
180303	DOUBLE HOSE BARB
180411	TEE-NIPPLE FOR BY PASS "BTM"
180421	HOSE BARB "T"
190231	UPPER ARM SUPPORT FC2006
190232	LOWER ARM SUPPORT FC2006
191111	BREAK TANK (SOFTENER)
200117	RUBBER HOSE 7X16
200122	HOSE 11X19
200416	GASKET D. 3/4"
200614	HOSE PUMP/SOFTENER
200615	HOSE PUMP/BREAK TANK
200709	RINSE PUMP INLET HOSE
200715	HOSE WATER INLET 2M STAINL.ST
200799	HOSE
200808	OR GASKET 3,53X50,80X57,86
201097	HOSE
260110	SCREW TE 8X10
300508	LOCK NUT 3/4"
301001	NIPPLE FE-ZN 3/4"
330725	STANDARD BRACKET F.SOLEN.VALV
450102	CLAMP FE ZN 11-17 H=9
450103	CLAMP FE ZN. 13-20 H=9
450114	CLAMP FE ZN.22-32 H=12,2
620209	INLET WATER FILTER
630987	COIL FOR SOFTENER
640222	WATER SOFTENER 0,7 LT
H35388	RINSE AID INJECTOR GF70/FC-E

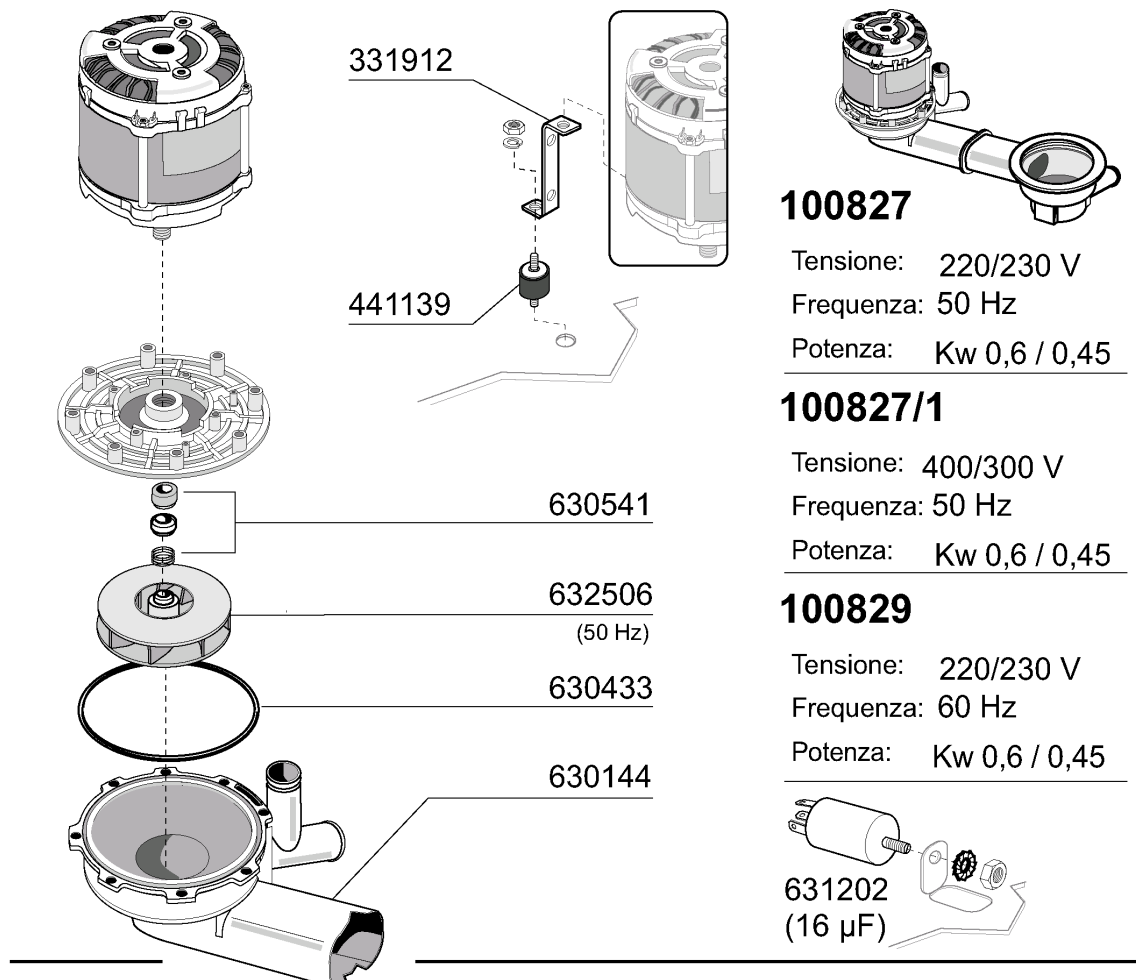

100827

Tensione: 220/230 V
 Frequenza: 50 Hz
 Potenza: Kw 0,6 / 0,45

100827/1

Tensione: 400/300 V
 Frequenza: 50 Hz
 Potenza: Kw 0,6 / 0,45

100829

Tensione: 220/230 V
 Frequenza: 60 Hz
 Potenza: Kw 0,6 / 0,45

Risciacquo - Rincage - Rinse - Aclarado - Nachspülpumpe

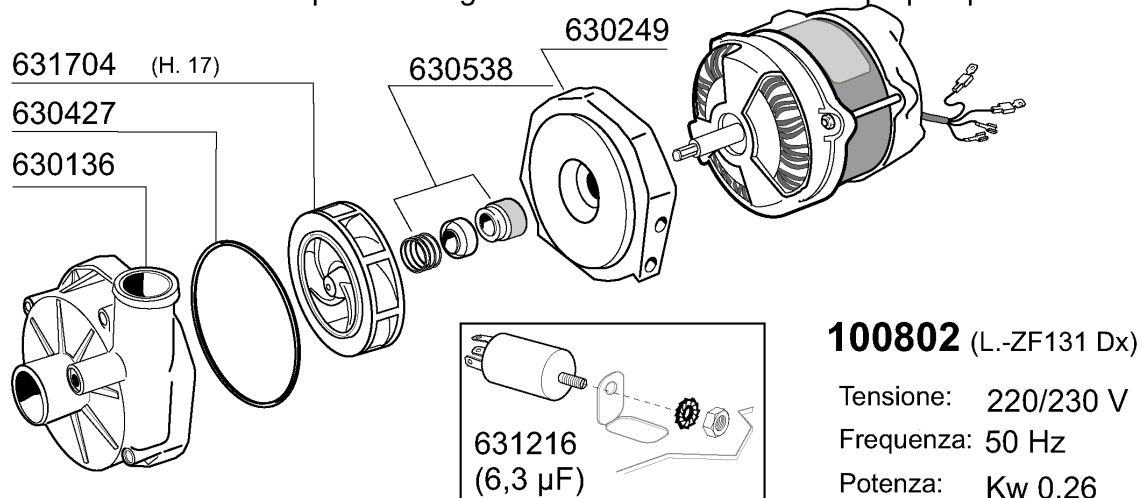

100802 (L.-ZF131 Dx)

Tensione: 220/230 V
 Frequenza: 50 Hz
 Potenza: Kw 0,26

05- 2011 | M. SA.

8 - Pump

CODE	DESCRIPTION
100802	PUMP HP 0,3 230V-50HZ
100827	WASH PUMP HP0,6 FC2006
100827/1	PUMP HP 0,6 LGB FC06 400/3/50
100829	PUMP HP 0,6 LGB FC06 60HZ
331912	BRACKET
441139	VIBRATION-DAMPING FEET 25X20X6
630136	PUMP VOLUTE LGB ZF131DX
630144	PUMP VOLUTE
630249	PUMP FLANGE ZF131 DX
630427	O-RING FOR PUMP ZF131DX
630433	GASKET FOR PUMP 100827
630538	SEAL LGBZF131DX
630541	SEAL FOR PUMP 100827
631202	CONDENSER 16 MF 450V
631216	CAPACITOR 6.3 MF 450V
631704	PUMP IMPELLER ZF131DX
632506	PUMP IMPELLER 100827 50HZ

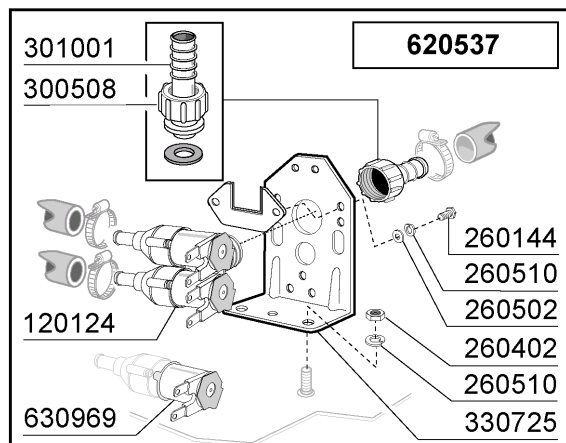
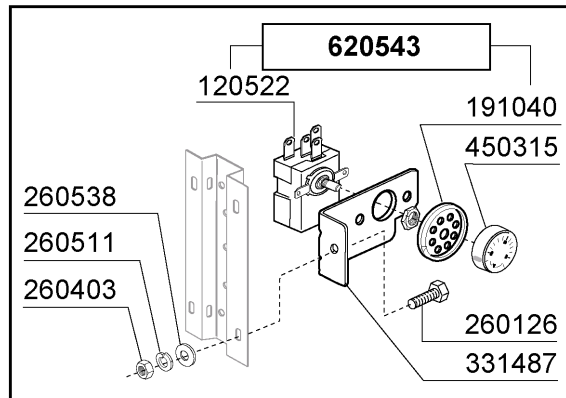
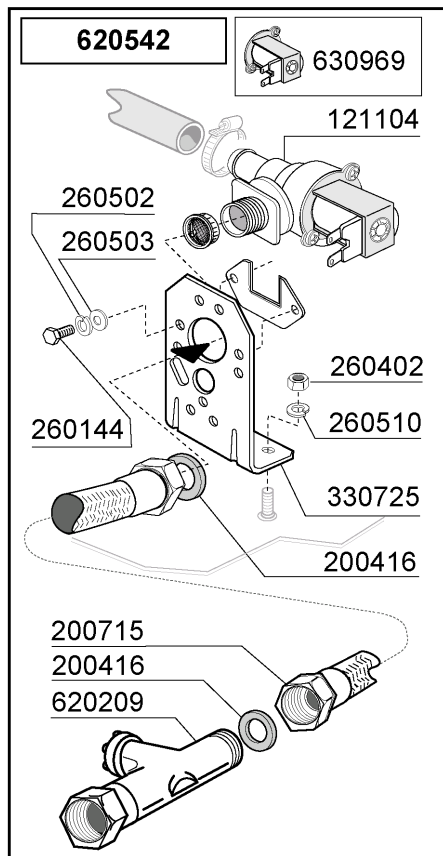
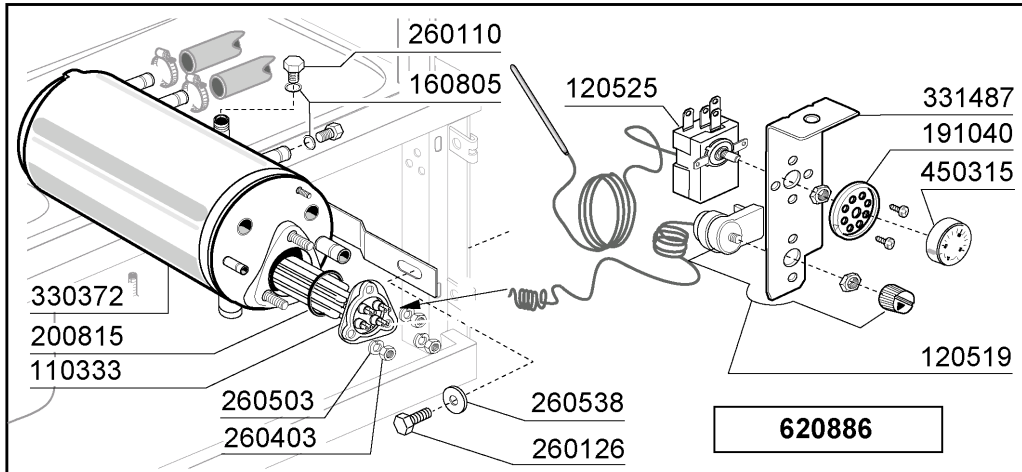

Aggiornato al: 04 Maggio 08

05 - 2008 | M. SA.

9 - Thermostat/solenoid valve

CODE	DESCRIPTION
110333	HEATER 7KW 230/400V
120124	2-WAY SOLENOID VALVE 230V 90Ø
120519	SECURITY THERMOSTAT 95-125Ø
120522	TANK THERMOSTAT 90Ø
120525	BOOSTER THERMOSTAT 2 TEMPERAT.
121104	SOLENOID VALVE 8 LT/M
160805	GASKET D.8
191040	FRAME F.THERMOSTAT KNOB
200416	GASKET D. 3/4"
200715	HOSE WATER INLET 2M STAINL.ST
200815	O-RING F. HEAT.ELEM.
260110	SCREW TE 8X10
260126	SCREW TE 5X12
260144	SCREW TE 4X6
260402	STAINLESS STEEL NUT D4 UNI 55
260403	NUTS D.5
260502	S/S FLAT WASHER D.4
260503	STAINL.STEEL FLAT WASHER D5 UN
260510	GROWER WASHER D.4
260511	GROWER WASHER D.5
260538	WASHER 18X6X1,5 ST/ST
300508	LOCK NUT 3/4"
301001	NIPPLE FE-ZN 3/4"
330372	BOILER FC2006
330725	STANDARD BRACKET F.SOLEN.VALV
331487	BRACKET FOR 1 THERMOSTAT
450315	KNOB F. THERMOSTAT 90Ø
620209	INLET WATER FILTER
620537	2-WAY SOLENOID VALVE
620542	SOLENOID VALVE ASSY
620543	TANK THERMOSTAT ASSY
620886	THERMOSTATS KIT FCM
630969	COIL S4216 220/50HZ

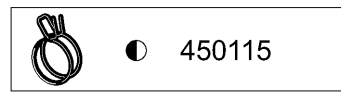
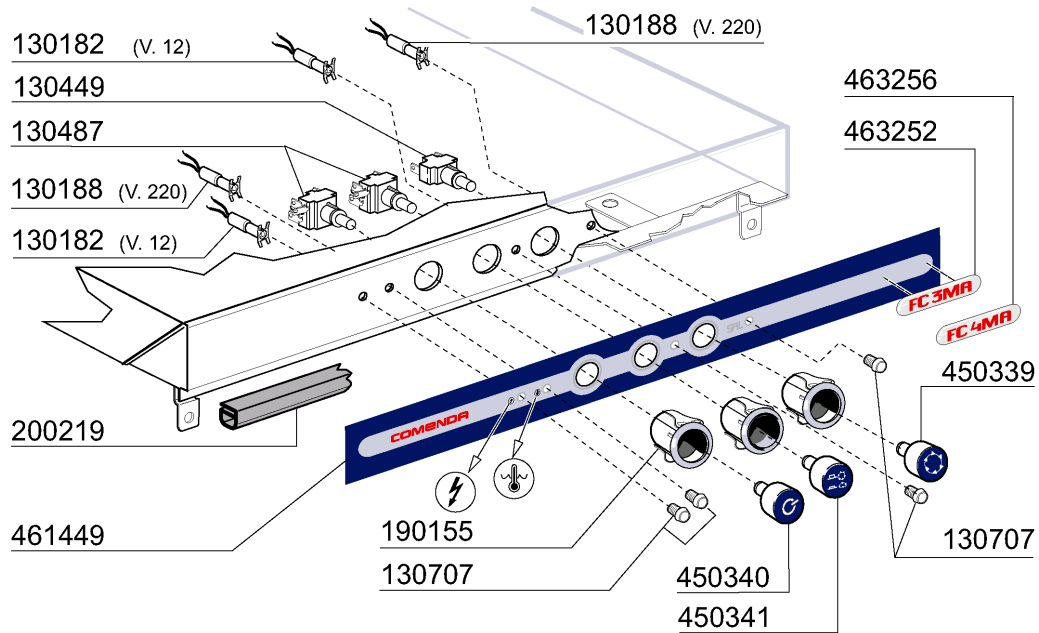

113271

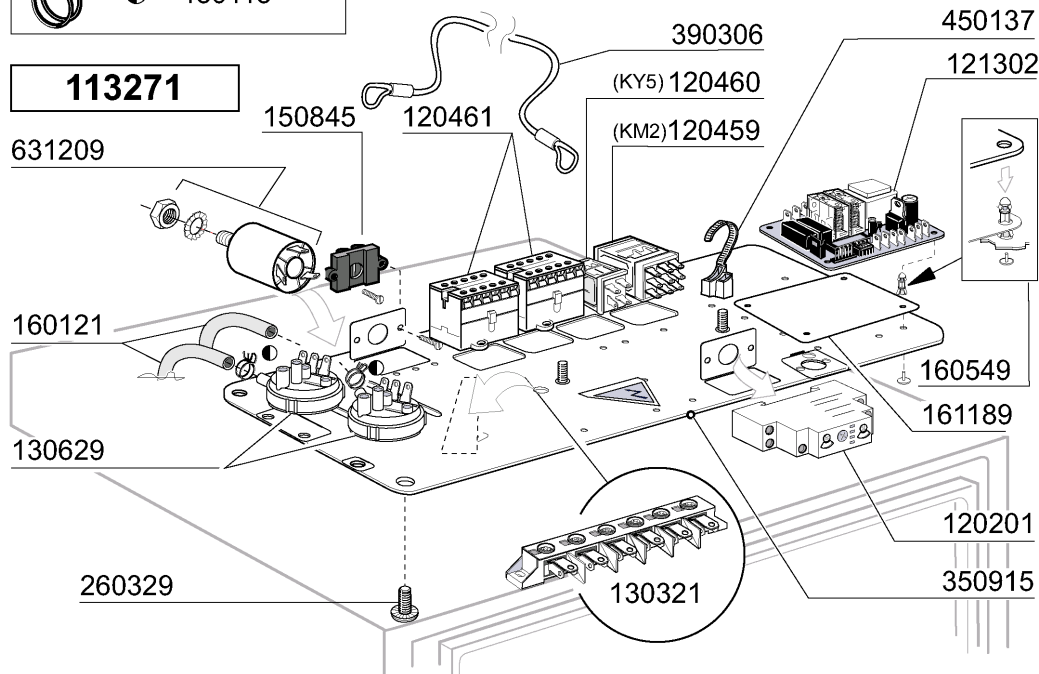

07 - 2010 | M. SA.

10 - Control box

CODE	DESCRIPTION
113271	CABLE FCMA
120201	TIMER FC MA
120459	AUXIL.RELE 16A 220V
120460	RELAY 16A 220V
120461	CONTACTOR ABB B6-30-01 220V
121302	PCB FCM
130182	GREEN LAMP 12V
130188	GREEN LED 220V
130321	JUNCTION BOX 6 CONNECTORS
130449	PUSH BUTTON BR-BC-FC
130487	SWITCH
130629	PRESSURE SWITCH 1L30-12
130707	TRANSPARENT LENS COVERS (C-SER
150845	PRESSACAVO SERIM 4228B
160121	HOSE EPDM D. 5 X 9
160549	SUPPORT
161189	COVER
190155	BUTTON HOLDER
200219	RUBBER GASKET
260329	VITE M5X12 SPEC.ZIGR.SOTTOTEST
350915	CONTROL PANEL SUPPORT
390306	CABLE
450115	ELASTIC CLAMP D.8,3/7,8
450137	COLLAR CONNECTION WITH BASE 31
450339	PUSH BUTTON "CYCLE"
450340	PUSH BUTTON
450341	PUSH BUTTON
461449	LABEL FCMA
463252	FC3M NAME
463256	FC4M NAME
631209	ANTI-NOISE FILTER

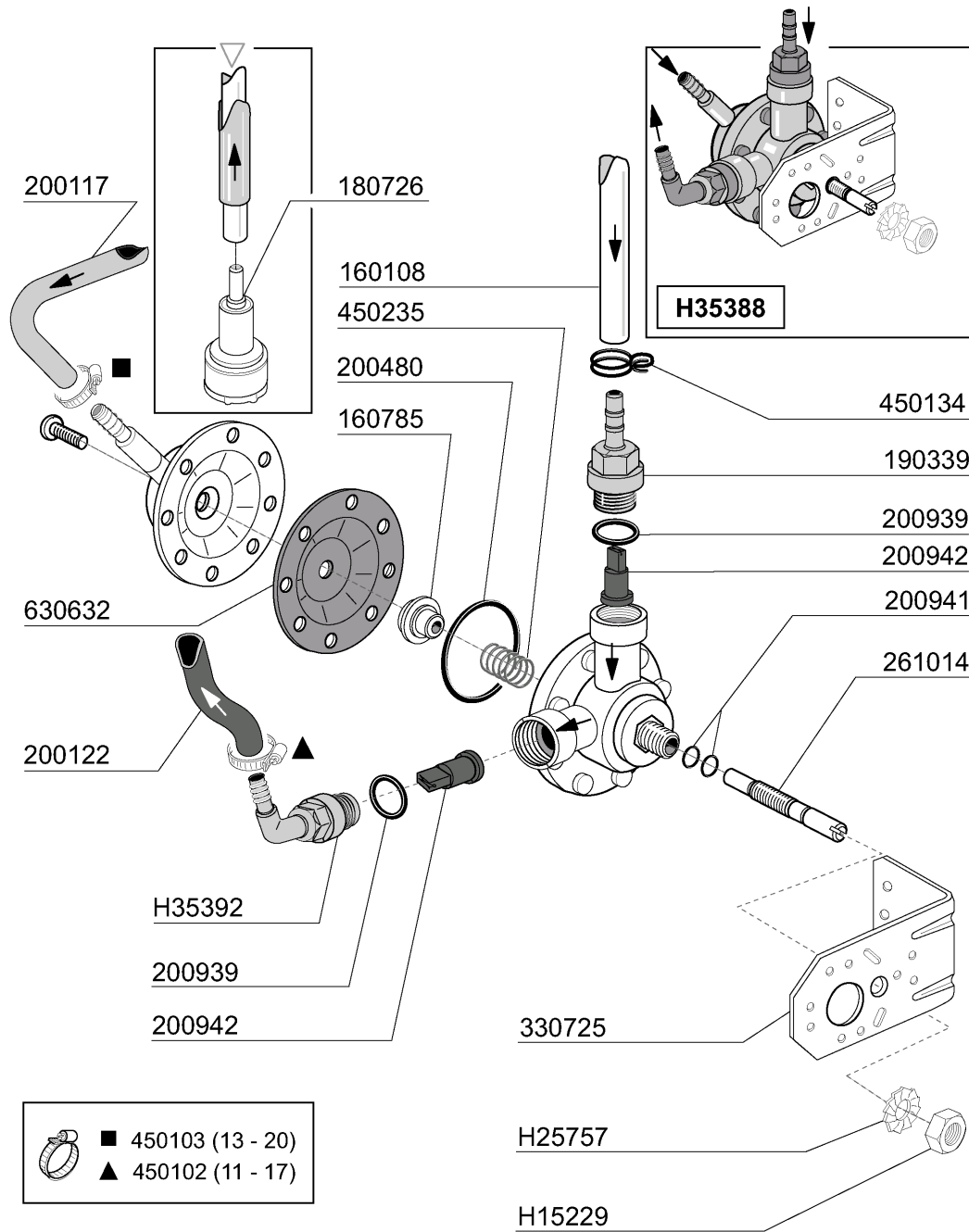

03 - 2008 | M. SA.

11 - Rinse aid injector

CODE	DESCRIPTION
160108	INJECT.INLET HOSE D.8X5
160785	GUIDE FOR SPRING RINSE AID INJ
180726	STREINER FOR RINSE AID INJECTO
190339	RINSE AID INJECTOR CONNECTION
200117	RUBBER HOSE 7X16
200122	HOSE 11X19
200480	GASKET F. RINSE CONNECT.
200939	OR GASKET
200941	OR GASKET
200942	VALVE RINSE INJECTOR HVD
261014	SCREW
330725	STANDARD BRACKET F.SOLEN.VALV
450102	CLAMP FE ZN 11-17 H=9
450103	CLAMP FE ZN. 13-20 H=9
450134	ELASTIC HOSE CLIP D.9,3/8,8
450235	SPRING RINSE AID INJECTOR
630632	DIAPHRAGM RINSE INJECTOR HVD
H15229	NUT
H25757	S/S FLAT WASHER
H35388	RINSE AID INJECTOR GF70/FC-E
H35392	NIPPLE

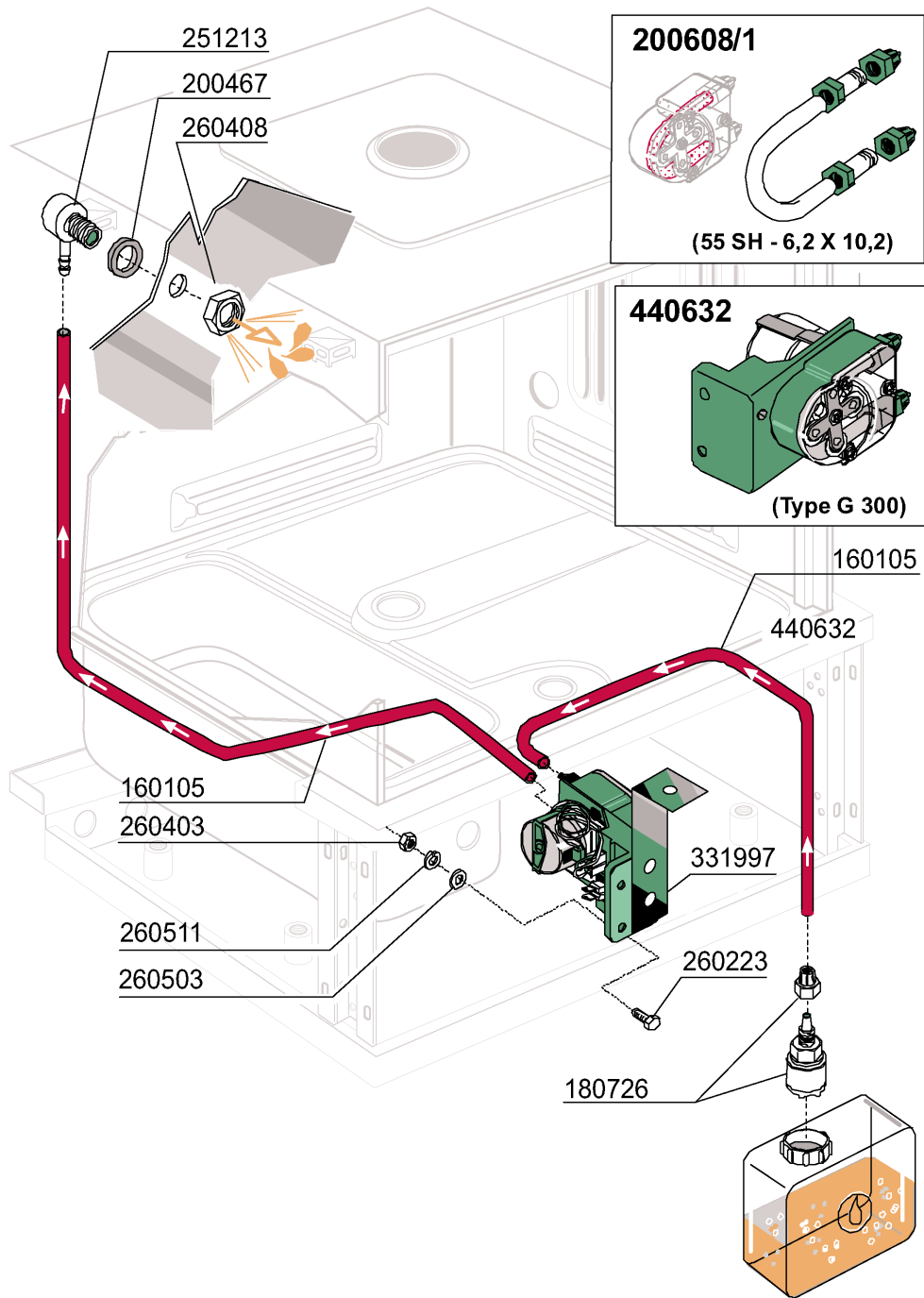

03 - 2008 | M. SA

12 - Detergent dispenser

CODE	DESCRIPTION
160105	INJECT.INLET HOSE D.6X4
180726	STREINER FOR RINSE AID INJECTO
200467	DUTRAL GASKET F. AIR TRAP
200608/1	HOSE FOR DISPENSER GERMAC G300
251213	INJECTIOR S/S FOR DETERGENT IN
260223	M5X12 MSH/HD SCREW SPECIAL S/S
260403	NUTS D.5
260408	S/S NUTS D.12
260503	STAINL.STEEL FLAT WASHER D5 UN
260511	GROWER WASHER D.5
331997	BRACKET
440632	DETERGENT INJECTOR